



# SJ60 AJ+

## ARTICULATING BOOMS



### STANDARD FEATURES

- EASYDRIVE™ Direction sensing drive and steer controls
- SPEEDYREACH™ Negative boom angle capability
- SKYRISER™ True vertical rise
- AXLDRIIVE™ Axle-based 4WD system
- Operator controlled locking rear differential and limited slip front differential
- Oscillating steer axle
- Drivable at full height
- 40% Gradeability
- Wet disc SAHR brakes (Front and rear axle)
- Grip lug foam filled tyres
- Dual module control system with SKYCODED™ colour coded and numbered wiring
- SMARTORQUE™ Kubota D1305 Stage V diesel engine
- Swing up cowlings for easy access
- Proportional controls
- 300kg / 454kg Dual capacity
- 0.91 x 2.44 m Platform
- Bolt-in platform railings
- Lanyard attachment points
- Tri-entry sliding mid rails
- Secondary Guarding Electrical (SGE)
- Overload sensing system
- Wiring for AC outlet on platform
- Tilt alarm (5.0° x 5.0°) with drive and lift cut-out
- Single point emergency lowering
- 360° Continuous turret rotation
- Tie down/lifting lugs
- Hourmeter
- Operator horn
- Lockable power disconnect switch



- 16% weight reduction
- 62% less fuel\*



- Reduced emissions



- 3% reduction in engine noise (excl. alarms)
- White noise alarm – *optional*



- 85% recyclable (by weight)



- ECOSTART (Stop-Start system) – *optional*
- HVO compatible
- Bio-degradeable hydraulic oil – *optional*



- Telematics – Remote diagnostics reduces site visits (operational carbon footprint)

\*Compared to SJ63 AJ Stage IIIB



ENG 07/2022

Preliminary specifications at time of printing.

† Standard lead times may be increased when optional equipment is added, consult factory.

‡ Capacities and machine weights may differ when options are added.

**SKYJACK**  
simply reliable™

# SJ60 AJ+ ARTICULATING BOOMS

Dimensions	SJ60 AJ+
Work Height	20.29 m
Platform Height	18.29 m
Horizontal Reach	11.56 m
Up and Over Height	8.31 m
<b>A</b> Platform Size	0.91 x 2.44 m
<b>B</b> Stowed Width	2.44 m
<b>C</b> Tailswing	0.61 m
<b>D</b> Stowed Height	2.54 m
<b>E</b> Transportation Height	2.79 m
<b>F</b> Stowed Length	8.59 m
<b>G</b> Transportation Length	6.60 m
<b>H</b> Wheelbase	2.44 m
<b>I</b> Ground Clearance	0.33 m

Specifications	SJ60 AJ+
Rotation	360° Continuous
Platform Rotation	170°
Jib Length	1.52 m
Jib Range +/-	+65° / -60°
Weight	8,557 kg
Gradeability	40%
Turning Radius (Inside)	2.21 m
Turning Radius (Outside)	5.31 m
Axle Oscillation	10.16 cm
Drive Speed (High speed)	4.0 km/h
Capacity	300 / 454 kg
Maximum Wind Speed	12.5 m/s
Personnel Rating at Max Wind Rating	2 / 3
Tyre Size	14 x 610
Tyre Type	Foam-Filled
Diesel Engine	Kubota D1305 18.5 KW (24.8 HP)
Fuel Tank Capacity	115L
Hydraulic Reservoir	115L

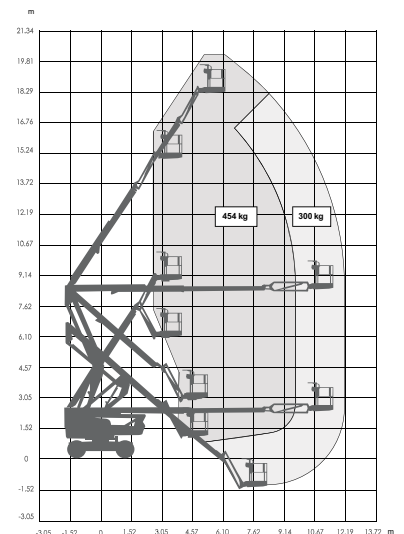
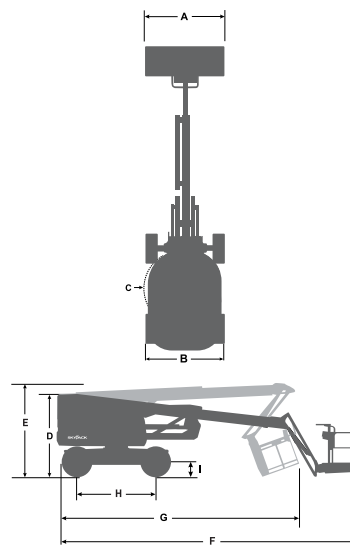

**SJ60 AJ+ WORKING ENVELOPE**

## ACCESSORIES

- Glazier kit
- Pipe rack
- Tool caddy

## OPTIONS

- Flashing light
- All motion audible alarm
- 0.91 x 1.83 m Platform
- Side spring hinged entry gate
- Auxiliary top rail (0.91 x 2.44 m platform only)
- 3.5 kW Generator
- Control box cover
- Grip lug foam filled non-marking tyres
- Cold weather start kit\*
  - \*Recommended for regions where average monthly low temperatures can reach 14°F / -10°C (Includes cold start engine oil, battery blanket, and hydraulic tank heater)
- Arctic weather package\*
  - \*Recommended for regions where average monthly low temperatures can reach -0.4°F / -18°C (Includes arctic engine oil, battery blanket, hydraulic tank heater, block heater, arctic hydraulic oil, and arctic gear oil in the axles and swing drive. Glow plugs, arctic hydraulic hoses (all), arctic platform rotator and oversized foot switch cover are also included (standard equipment).)
- ECOSTART (anti-engine idle)
- Diesel scrubber
- Bio oil
- ELEVATE telematics

[www.skyjack.com](http://www.skyjack.com)

**Skyjack UK**  
 Unit 1, Maes-y-Clawdd  
 Maesbury Road Industrial Estate  
 Oswestry, Shropshire, SY10 8NN  
 Tel: +44 1691 676235  
 Fax: +44 1691 676239  
 Email: info@skyjackeurope.co.uk

**Skyjack SAS (France)**  
 74 Rue Sibert  
 F-42400 Saint Chamond  
 France  
 Tel: +33 (0) 4 78 73 53 32  
 Fax: +33 (0) 4 78 56 52 42

**Skyjack Hebebühnen GmbH (Germany)**  
 Därmannsbusch 2a  
 D-58456 Witten  
 Tel: +49 (0) 2302 20 26 909  
 Fax: +49 (0) 2302 20 25 671

**Skyjack AB (Sweden)**  
 Agnesbergsvägen 28  
 424 38 Agnesberg  
 Sweden  
 Tel: +46 (0) 31 21 22 45  
 Fax: +46 (0) 31 787 65 10

**SKYJACK**  
 simply reliable